

ProfitLine PRR

The industrial system for smoking and cooking



Advantages

Wide variety of flavours and colours

All external and various internal smoke generation systems, such as smouldering smoke, condensate smoke, friction smoke or liquid smoke, are available for smoking.

Efficiency

Due to two fans an extensive air circulation guarantees constant product quality with minimum weight loss upon drying and smoking despite maximum trolley loading.

Designed for industry

- Wide door opening clearance
- The central air conditioning system incorporates all required equipment such as a heat exchanger, a central circulation fan, an air alternating damper, fresh air and smoke supplies and a mixing chamber for air conditioning.

Minimum energy consumption

Individual air circulation and optimal use of fresh air energy during drying enormously reduce your process times and thus the energy requirements. The system as well as the air handling unit are fully insulated.

Good to know

Use

ProfitLine systems are universal allrounders due to the horizontal and vertical air circulation, regardless whether products are placed horizontally on grates or suspended on smokesticks.

Possible processes

- drying, showering
- hot and cold smoking
- cooking, hot air finishing, roasting and baking

Air systems

- Two variable-speed fans within the program step
- The air is optimally adjustable to the corresponding product
- A very high uniformity is provided by the enormous air circulation speed, even with trolleys > 2 m height
- Fully insulated central air handling unit (very high air speed in contact with the products)

Hygiene

- Segment construction, completely weldable
- Automatic interior cleaning

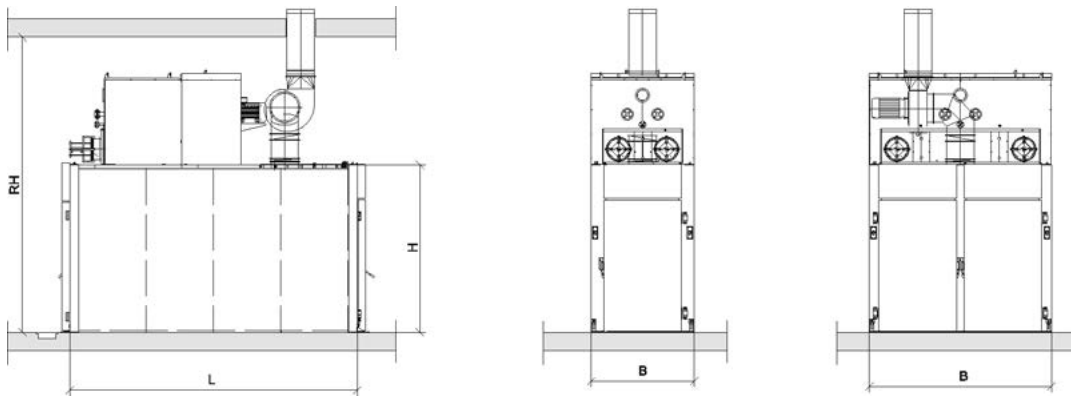

	PRR type	Number of trolleys	Door opening clearance (cm)		Cabinet dimensions (incl. extension) (cm)			Minimum room height (aggregate on top) (cm)	Electric kW [⊖]	Heating Steam kW [⊖]	Heating Electric kW [⊖]	Heating Oil; Gas kW [⊖]	Cooling system Cold smoke from-to kg/h [⊖]	Low pressure steam / Water Cooking l/min [⊖]	Water Shower kg		
			width	height	height [H]	width [B]	length [L] [⊖]									height [RH]	
Tandem	1043	4	120	210	275	170	473	400	23	140	120	160	20-40	187	50		
	1053	5	120	210	275	170	584	450	31	174	150	200	25-50	234	60		
	1063	6	120	210	275	170	695	450	38	209	180	240	30-60	281	70		
	1073	7	120	210	275	170	806	480	38	244	210	280	35-70	327	80		
	1083	8	120	210	275	170	917	480	45	279	240	320	40-80	374	90		
Parallel	2063	6	(2x) 120	210	275	300	362	450	38	209	180	240	30-60	281	70		
	2083	8	(2x) 120	210	275	300	473	480	45	279	240	320	40-80	374	90		
	2103	10	(2x) 120	210	275	300	584	500	61	349	300	400	50-100	468	110		
	2123	12	(2x) 120	210	275	300	695	500	75	419	360	480	60-120	561	130		
also to be considered			wedge (2x for tunnel)				plus 15										
			without tunnel				minus 8.5										
			overhead rail		on request				on request								
			lifting doors						min. 500								
			aggregate at rear / at side		possible / [RH] reduced to 350-400												

⊖ with tunnel
 ⊖ approximately connected loads

Features	Description	Standard	Options	Further data sheets
Operation	external operating controls	x		Control and documentation system
Standard heating (optional)	electric (160 °C)	x		
	low pressure (80 °C)	x		
	high pressure (120 °C)	x		
	oil (160 °C)	x		
	gas (160 °C)	x		
Additional heating	gas or electric up to max. 200 °C		x	
Smoke	external smoke generator		x	External smoke generators
	internal smoke generator		x	Internal smoke generators
	RONDAIR exhaust reduction system		x	
	exhaust air cleaning		x	Environment and energy efficiency system
Cleaning	interior cleaning	for PRR systems	for PK systems	
	cleaning equipment		x	Cleaning system
Cooking	chamber 1.4571 / AISI 316	for PK systems	for PRR systems	
Exhaust air system	exhaust air fans	for PRR systems	for PK systems	
Cold smoke	cooling system		x	
Cooling	showering		x	
	ice water		x	Environment and energy efficiency system
Horizontal air flow	horizontal air circulation system		up to 1063 / 2083	
Floor	double-walled, without slope	x		
	slope in the system		x	
	reinforced		x	
	recessed		x	
	anti-slide profile		x	
Doors	lifting door hinge	x		
Tunnel design	additional doors on the unloading side		x	
	interlocking		x	
Lifting doors	instead of swing doors		x	
Drainage	pneumatic post outlet	x		
	automatic door opening		x	
Transport systems	floor transport (automatic)		x	Semi-continuous batch system
	overhead rail (automatic)		x	Semi-continuous batch system
	overhead rail with max. 1t/cart place (man.)		x	