

DETAILED IMPROVEMENTS FOR HIGH-QUALITY RESULTS



120-litre vacuum cutter
VCM 120

NEW!



K+W WETTER



OPTIONAL COOKING DEVICE

Integrated directly into the double-walled bowl. Additional seals are unnecessary as the entire process takes place within a closed system. For shorter process times and less contamination and dirt.

120-LITRE VACUUM CUTTER

Success made easy

In our opinion, small details often make a big difference. And since it is important to us make your workday easier with our attention to detail, we have developed new, innovative solutions and have incorporated them directly into the new 120-litre vacuum cutter by K+G Wetter.

An essential feature is the split vacuum lid. Thanks to this solution, only the front section of the lid is opened, not the entire lid. This feature ensures faster, more comfortable and easier access to the cutter bowl. In addition, a new touch panel allows for intuitive operation. Knife and bowl speeds can be entered directly on the touch panel. You can also set switch-off functions, such as a temperature switch-off. The entire control system is incorporated into the compact machine so that more space is available for operation and no complicated wiring is required on the outside. Another clear advantage in terms of hygiene. Our better solution in detail makes for a simpler solution for your workday.

BUILT-IN QUALITY

This machine sets the highest hygiene standards and keeps your work area even cleaner. Easy access from two sides allows for optimal cleaning under the vacuum bowl – all areas are visible and easily inspected. The machine's sloped surfaces also guarantee complete drainage of cleaning liquid. For the best product results down to the smallest detail.

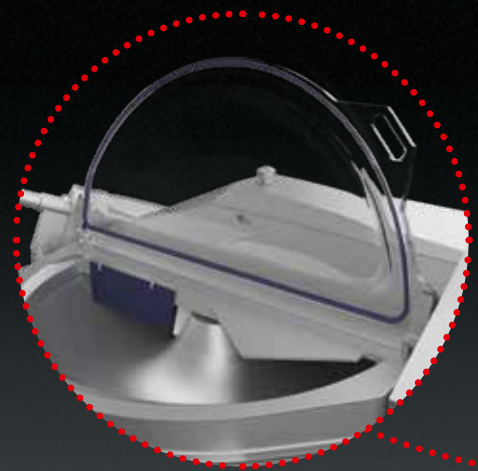

SPLIT VACUUM LID

A clever solution for quicker loading and unloading of the cutter bowl and shorter evacuation times.



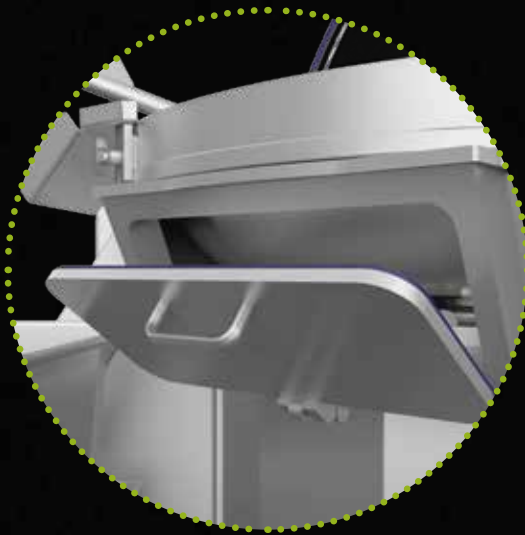

PRACTICAL KNIFE COVER

With removable baffle plate for optimal adjustment of the cutting space for each product.

SPACIOUS CLEANING ACCESS

Access to the underside of the bowl allows for simple, quick and very hygienic cleaning of the machine.



TECHNICAL DATA

	Vacuum-Cutmix VCM 120 STL	Vacuum-Cutmix VCM 120 T2M-R
Model	infinitely variable drive	two-speed drive
Type code	506	506
Electrical data		
rated power (incl. vacuum pump)	47 kW	47 kW
rated current (incl. vacuum pump)	95 A	95 A
obligatory pre-fusing at customer site	100 A gL/gG	100 A gL/gG
Rotation speed		
knives head	40...5000 min ⁻¹	1500/3000 min ⁻¹
mixing (forward and backward)	40...500 min ⁻¹	75/150 min ⁻¹
bowl drive	5...18 min ⁻¹	9/18 min ⁻¹
Rated power motors		
knives drive (three-phase servomotor)	40 kW	40 kW
bowl drive	1.4 kW	1.4 kW
Optimum batch size		
boiled sausages	96 kg	96 kg
cooked sausages	84 kg	84 kg
raw sausages	54 kg	54 kg

USER-FRIENDLY OPERATION

Innovative touch panel with a clean user interface design. All the important settings, such as knife and bowl speeds, switch-off functions, etc. can be freely configured.



STABLE MACHINE BASE

Cast in a single piece to ensure quiet operation, sound insulation, highest stability and long machine service life.

MORE FEATURES TO ENSURE YOUR SUCCESS:

- 9 programmable settings for knife speed with direct access (2 fixed speeds for T2M-R)
- infinitely variable bowl speed with 6 programmable speed settings (2 fixed speeds for T2M-R)
- special knife systems for each product and removable baffle plate ensure the best possible cutting process results
- optimal bowl and cutting space geometry and innovative drive units ensure high energy efficiency
- increased bowl edge prevents spilled sausage meat and reduces cleaning efforts
- optional hydraulic unloader available
- compact, hygienically-designed loader without exposed chains
- robust water ring vacuum pump with minimal water consumption
- can be combined with CutVision and CutControl software for recipe management and quality control
- integrated diagnostic system ensures maximum up-time and facilitates preventative maintenance
- integrated water drainage opening in the bowl provides complete drainage during cleaning, to prevent the need for hand contact and potential contamination

...and many more options

DIMENSIONS

VCM with feeder

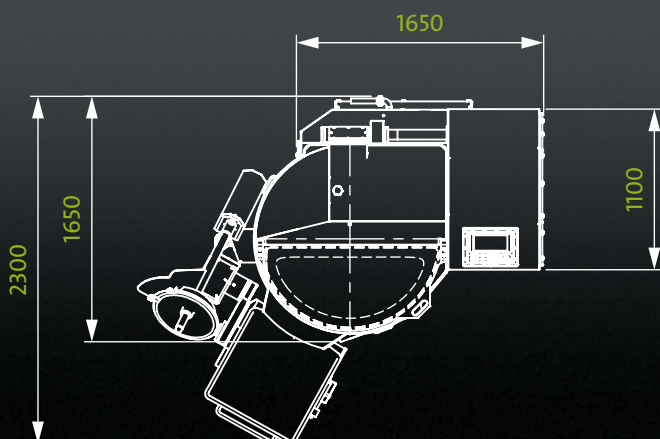
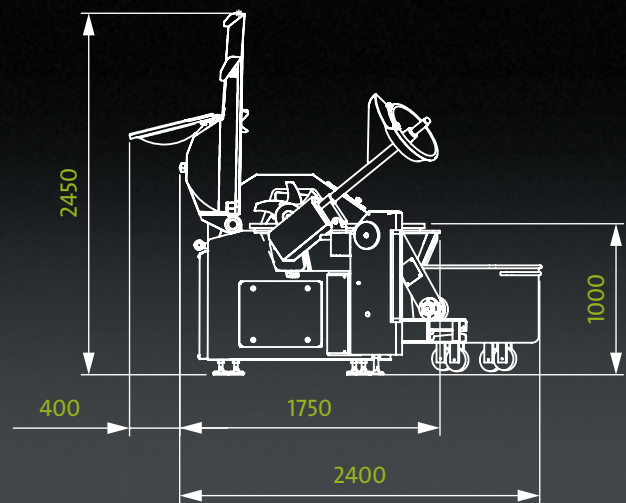
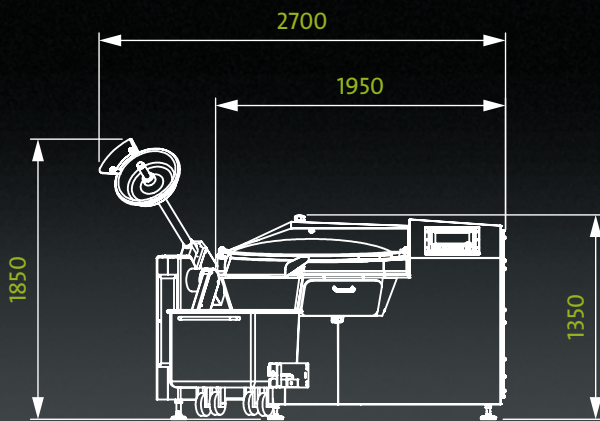



WE MAKE LIFE EASY FOR YOU!

.....

This is what we bring to the table.

For the past 25 years, we have been producing high-quality, reliable meat-processing machines. Our primary objective is to leverage our machines to make daily operations easier. This is why our experts are constantly fine-tuning new solutions that will make our machines work even better for you. We continuously guarantee the renowned quality of K+G Wetter machines by ensuring careful assembly of the various components, with our staff working on intricate detailing hands-on. From the surface to the knife head: K+G Wetter is 100% "Made in Germany".

We are available wherever you need us – worldwide. We place particular emphasis on reliability and robustness, not only in terms of our machines, but also when it comes to partnerships. We are always available to address your queries in person and will also be there for you if you should experience any problems. That is our promise to you!

**WE TACKLE IT ALL – FOR THE SAKE
OF WORKMANSHIP AND
THE TRADE. FOR THE SAKE OF
YOUR SUCCESS.**

Come and see for yourself. Call us at +49 (0) 64 61 / 98 40 - 0 or pay us a visit. Together, we will find the exact solution that wholly meets your individual requirements and operating processes. We look forward to meeting you!

MADE IN
GERMANY

K+G WETTER

K+G WETTER GmbH
Goldbergstraße 21
35216 Biedenkopf-Breidenstein

Phone +49 (0) 64 61 / 98 40 - 0
Fax +49 (0) 64 61 / 98 40 - 25

info@kgwetter.de
www.kgwetter.de